

The Net Zero Teesside Order 20[XX]

Regulation 5(2)(i) - Infrastructure Planning
(Applications: Prescribed Forms and Procedure)
Regulations 2009

Key

Order Land - the area within which powers of compulsory acquisition and to take temporary possession can be exercised

0 Sheet Location and Number

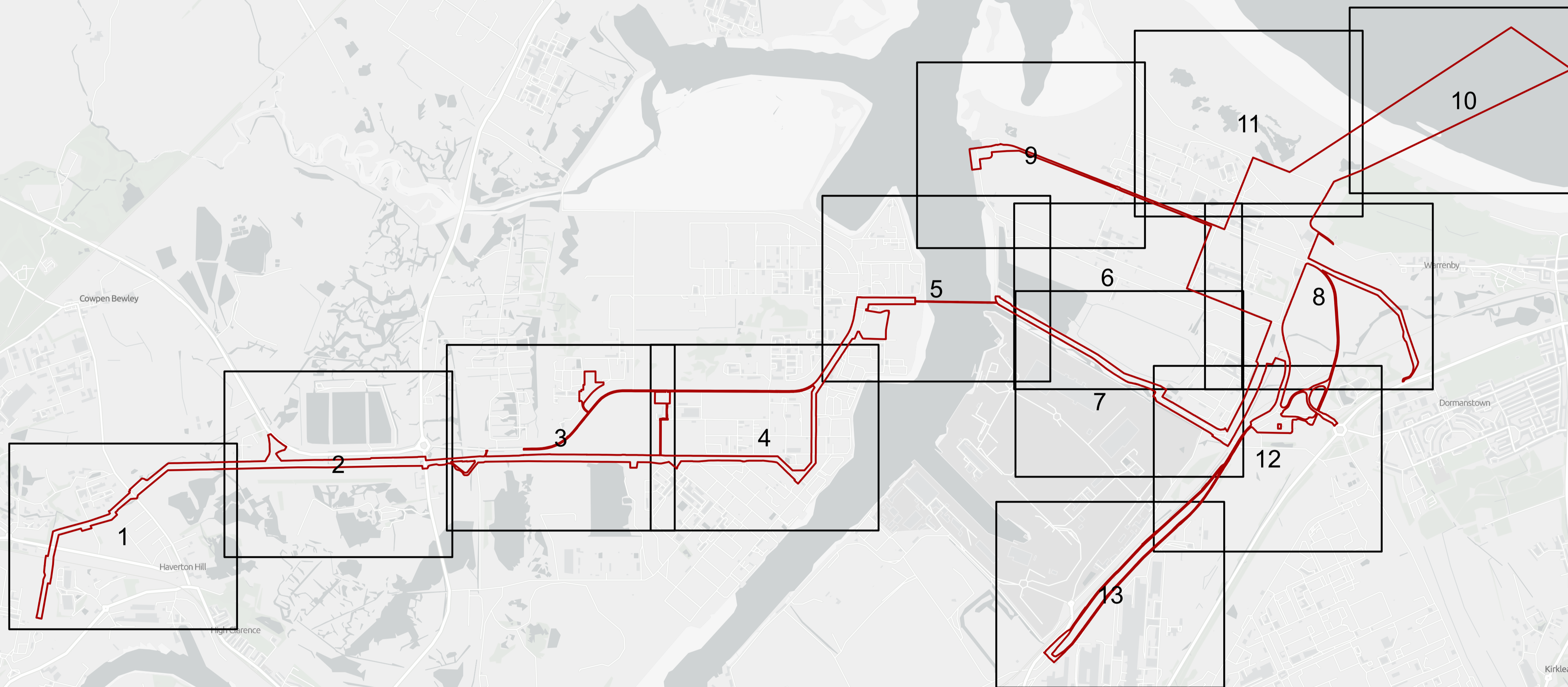

GB Light Grey: Contains OS data © Crown Copyright and database right 2022
Contains data from OS Zoomstack



Clients **NZT Power Limited & NZNS Storage Limited**

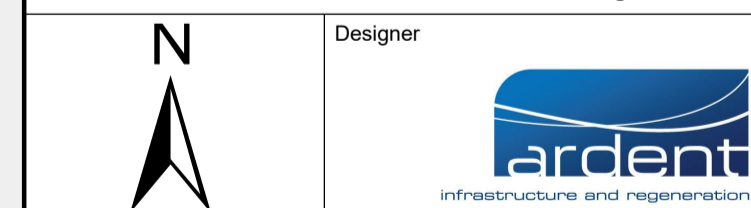

Project **NET ZERO TEESSIDE PROJECT**

Drawing Title
**APPLICATION DOCUMENT REFERENCE NO. 4.2
LAND PLANS
KEY PLAN**

Status	FOR INFORMATION	Revision	05
Date	October 2022		

Scale	1:20,000 @ A1	Spatial Reference System	British National Grid
-------	---------------	--------------------------	-----------------------

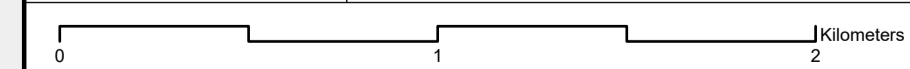

Drawn By	Checked By	Approved By
N.HENRYS	J.WITHINGTON	L.HARTIGAN

Drawing reference **026_ARDG_TCCC_LP_KEYPLAN**

This document is not to be used in whole or in part other than for the intended purpose and project for which it was prepared and provided.

Plot Date: 20 October 2022 15:08
 File Name: C:\Users\N1\OneDrive\Management Ltd\Ardent Management Ltd\Projects - P16 - GIS & CAD Files (2026_ARDG_TCCC\N1\Land Plans\026_ARDG_TCCC_LP_22.aprx

The Net Zero Teesside Order 20[XX]

Regulation 5(2)(i) - Infrastructure Planning
(Applications: Prescribed Forms and Procedure)
Regulations 2009

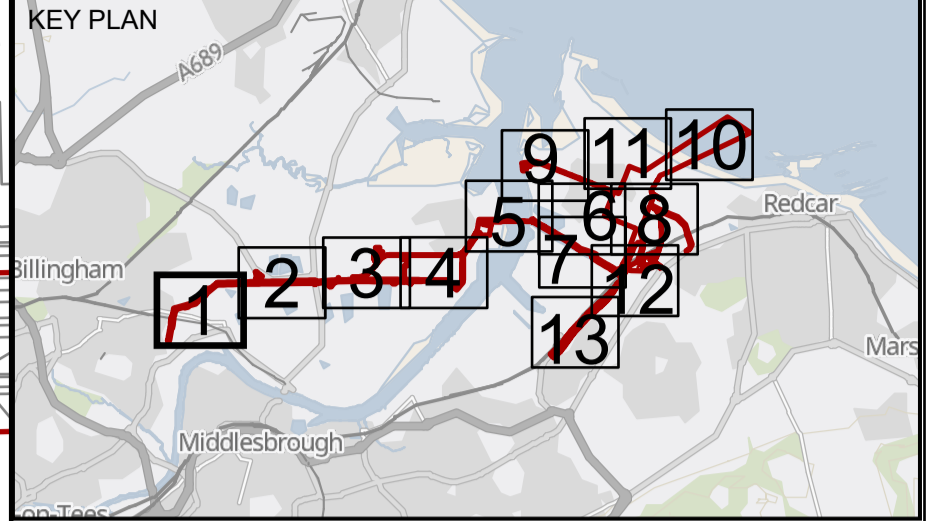

- Key**
- Order Land - the area within which powers of compulsory acquisition and to take temporary possession can be exercised
 - Order Land - New Rights to be compulsorily acquired and in relation to which it is proposed to extinguish easements, servitudes and other private rights.
 - Order Land - Freehold to be compulsorily acquired and in relation to which it is proposed to extinguish easements, servitudes and other private rights.
 - Order Land - Temporary use of land and in relation to which it is proposed to extinguish or suspend easements, servitudes and other private rights.
 - Special Category Land - Open Space

© Crown copyright and database rights 2020 Ordnance Survey 0100031673. You are permitted to use this data solely to enable you to respond to, or interact with, the organisation that provided you with the data. You are not permitted to copy, sub-licence, distribute or sell any of this data to third parties in any form.
GB Background: Contains OS data © Crown Copyright and database right 2022. Contains data from OS Zoomstack

Client: Net Zero Teesside

Clients: **NZT Power Limited & NZNS Storage Limited**

Designer: **ardent**
infrastructure and regeneration

Project: **NET ZERO TEESIDE PROJECT**

Drawing Title: **APPLICATION DOCUMENT REFERENCE NO. 4.2
LAND PLANS
SHEET 1 OF 13**

Status	FOR INFORMATION	Revision	05
Date		Date	October 2022
Scale	1:2,500 @ A1	Spatial Reference System	British National Grid
Drawn By	N.HENRY	Checked By	J.WITHINGTON
Approved By		Approved By	L.HARTIGAN
Drawing reference	026_ARDG_TCCC_LP		

This document is not to be used in whole or in part other than for the intended purpose and project for which it was prepared and provided.

Plot Date: 20 October 2022, 15:08
 File Name: C:\Users\NHC\Arden Management Ltd\Arden Management Ltd\Projects - P16 - GIS & CAD Files (2\026_ARDG_TCCC\MKD\Land Plans\026_ARDG_TCCC_LP_22.aprx

The Net Zero Teesside Order 20[XX]

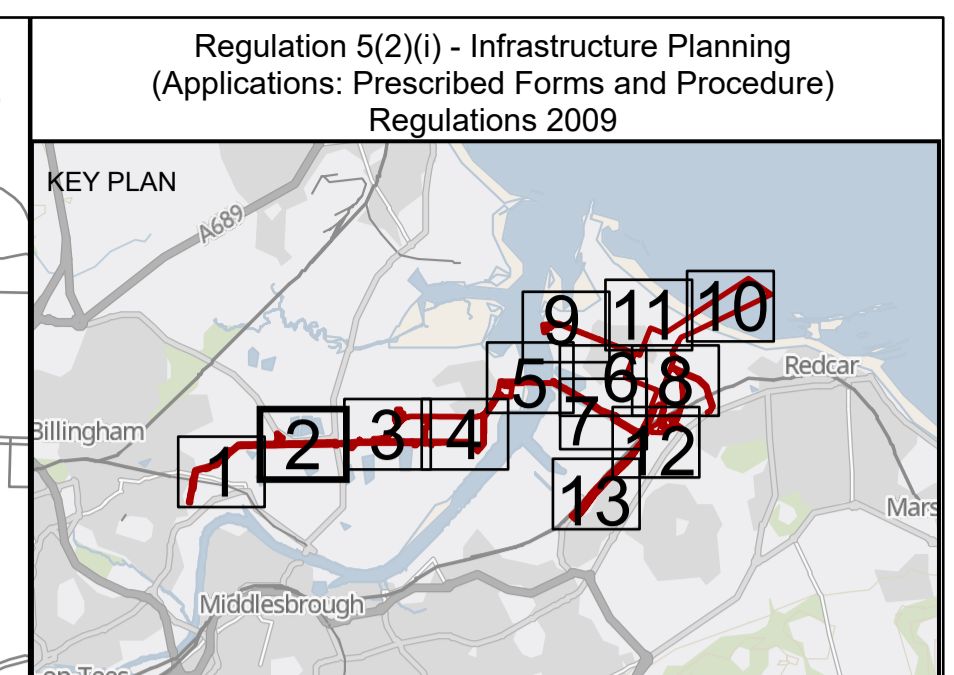
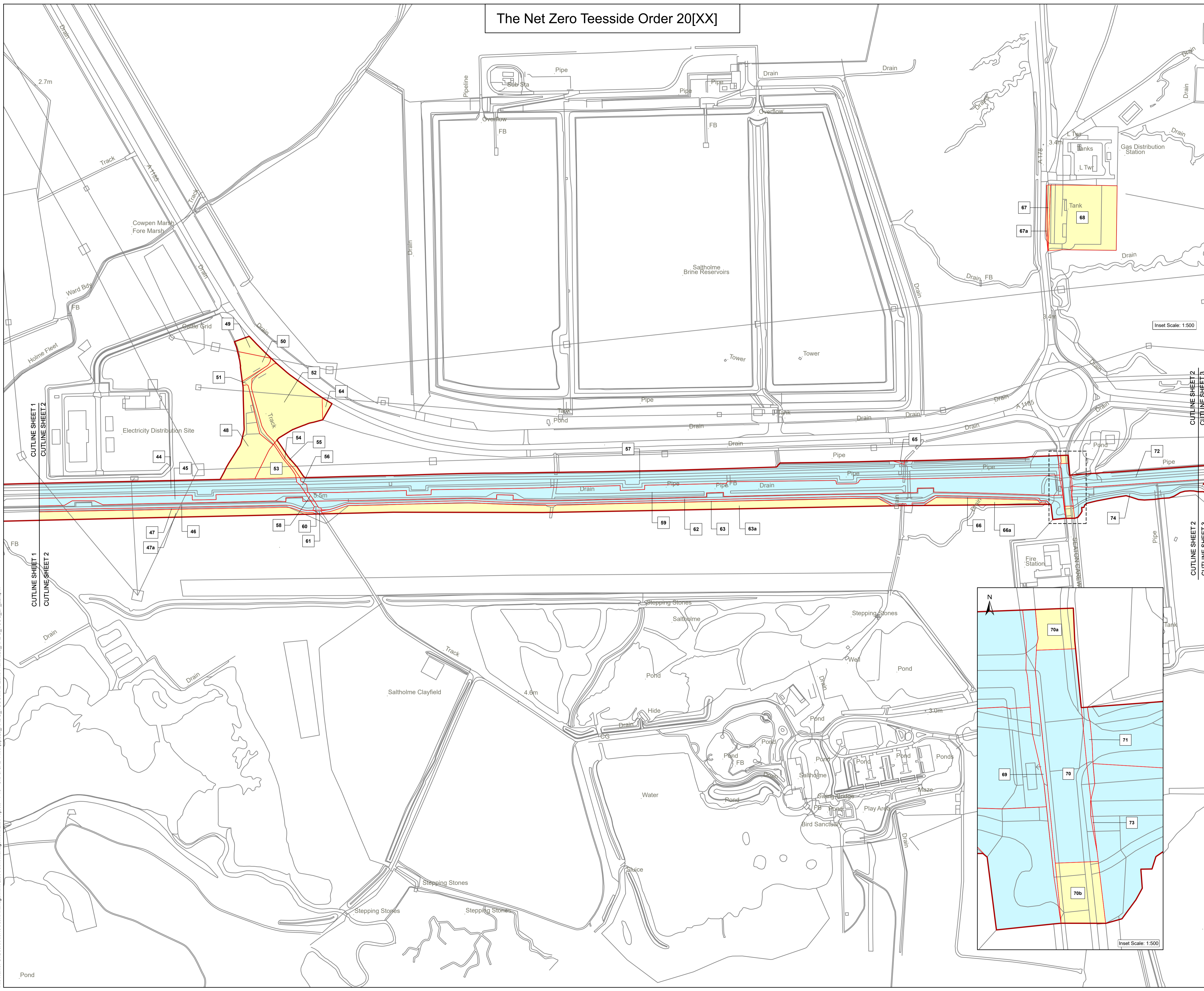

- Key**
- Order Land - the area within which powers of compulsory acquisition and to take temporary possession can be exercised
 - Order Land - New Rights to be compulsorily acquired and in relation to which it is proposed to extinguish easements, servitudes and other private rights.
 - Order Land - Freehold to be compulsorily acquired and in relation to which it is proposed to extinguish easements, servitudes and other private rights.
 - Order Land - Temporary use of land and in relation to which it is proposed to extinguish or suspend easements, servitudes and other private rights.
 - Special Category Land - Open Space

© Crown copyright and database rights 2020 Ordnance Survey 0100031673. You are permitted to use this data solely to enable you to respond to, or interact with, the organisation that provided you with the data. You are not permitted to copy, sub-licence, distribute or sell any of this data to third parties in any form.
 GB Background: Contains OS data © Crown Copyright and database right 2022. Contains data from OS Zoomstack

Client: Net Zero Teesside

Clients: **NZT Power Limited & NZNS Storage Limited**

Designer: ardent
 infrastructure and regeneration

Project: **NET ZERO TEESIDE PROJECT**

Drawing Title: **APPLICATION DOCUMENT REFERENCE NO. 4.2
 LAND PLANS
 SHEET 2 OF 13**

Status	FOR INFORMATION	Revision	05
Scale	1:2,500 @ A1	Date	October 2022
Spatial Reference System	British National Grid	Checked By	J.WITHINGTON
Drawn By	N.HENRY	Approved By	L.HARTIGAN
Drawing reference	026_ARDG_TCCC_LP		

This document is not to be used in whole or in part other than for the intended purpose and project for which it was prepared and provided.

Plot Date: 20 October 2022, 15:09
 File Name: C:\Users\NHC\Arden Management Ltd\Arden Management Ltd\Projects - P16 - GIS & CAD Files (2\026_ARDG_TCCC\KMLand Plans\026_ARDG_TCCC_LP_22.aprx

The Net Zero Teesside Order 20[XX]

Regulation 5(2)(i) - Infrastructure Planning (Applications: Prescribed Forms and Procedure) Regulations 2009

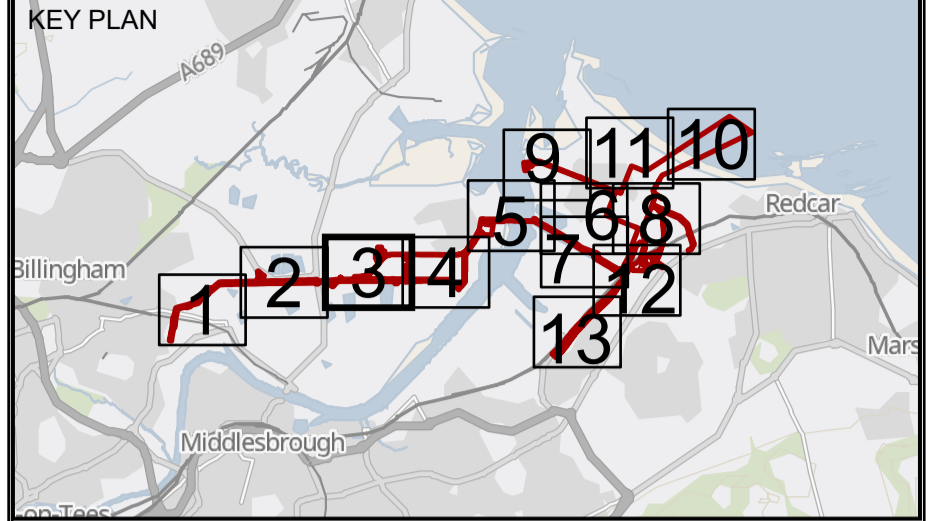

- Key**
- Order Land - the area within which powers of compulsory acquisition and to take temporary possession can be exercised
 - Order Land - New Rights to be compulsorily acquired and in relation to which it is proposed to extinguish easements, servitudes and other private rights.
 - Order Land - Freehold to be compulsorily acquired and in relation to which it is proposed to extinguish easements, servitudes and other private rights.
 - Order Land - Temporary use of land and in relation to which it is proposed to extinguish or suspend easements, servitudes and other private rights.
 - Special Category Land - Open Space

© Crown copyright and database rights 2020 Ordnance Survey 0100031673. You are permitted to use this data solely to enable you to respond to, or interact with, the organisation that provided you with the data. You are not permitted to copy, sub-licence, distribute or sell any of this data to third parties in any form.
GB Background: Contains OS data © Crown Copyright and database right 2022. Contains data from OS Zoomstack

Client: Net Zero Teesside

Clients: **NZT Power Limited & NZNS Storage Limited**
Designer: ardent infrastructure and regeneration

Project: **NET ZERO TEESIDE PROJECT**
Drawing Title: **APPLICATION DOCUMENT REFERENCE NO. 4.2 LAND PLANS SHEET 3 OF 13**

Status: FOR INFORMATION	Revision: 05
Scale: 1:2,500 @ A1	Date: October 2022
Spatial Reference System: British National Grid	

Drawn By: N.HENRYS	Checked By: J.WITHINGTON	Approved By: L.HARTIGAN
---------------------------	---------------------------------	--------------------------------

Drawing reference: **026_ARDG_TCCC_LP**
This document is not to be used in whole or in part other than for the intended purpose and project for which it was prepared and provided.

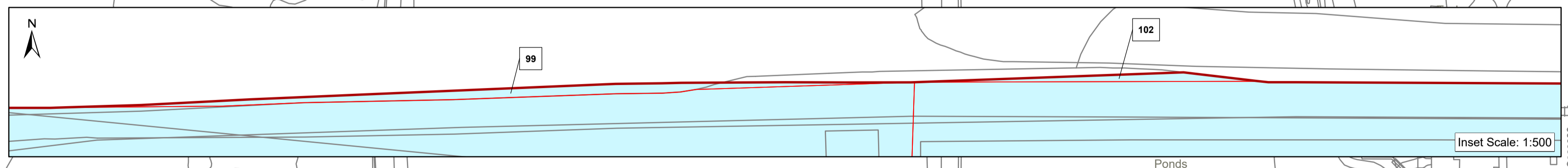
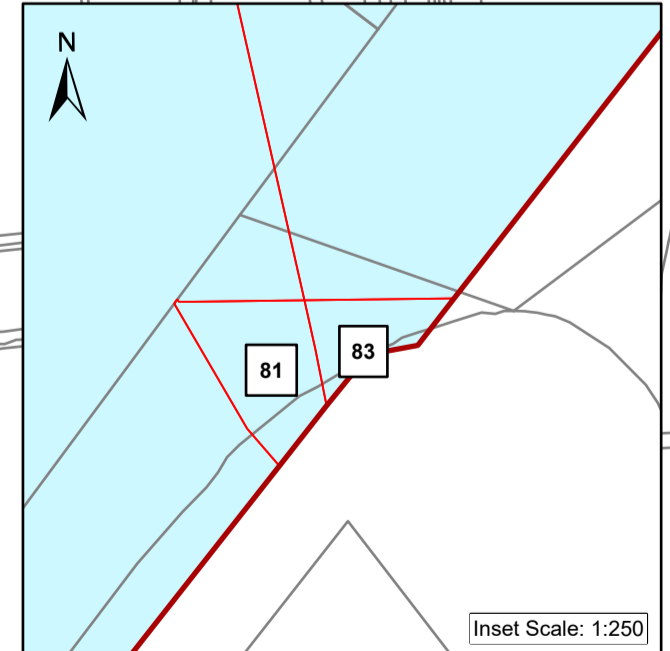
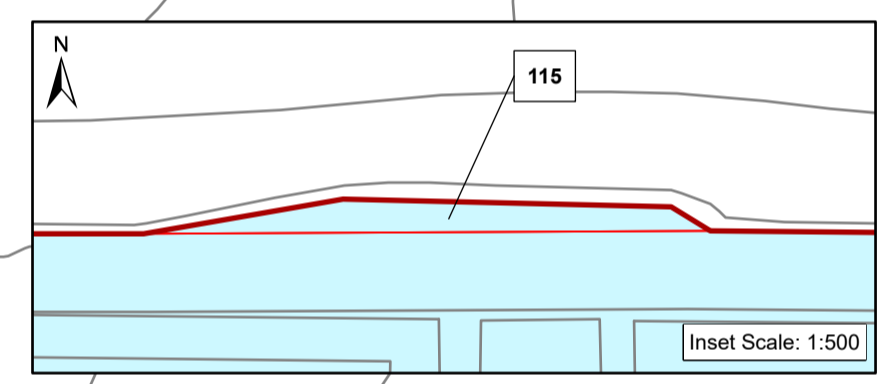
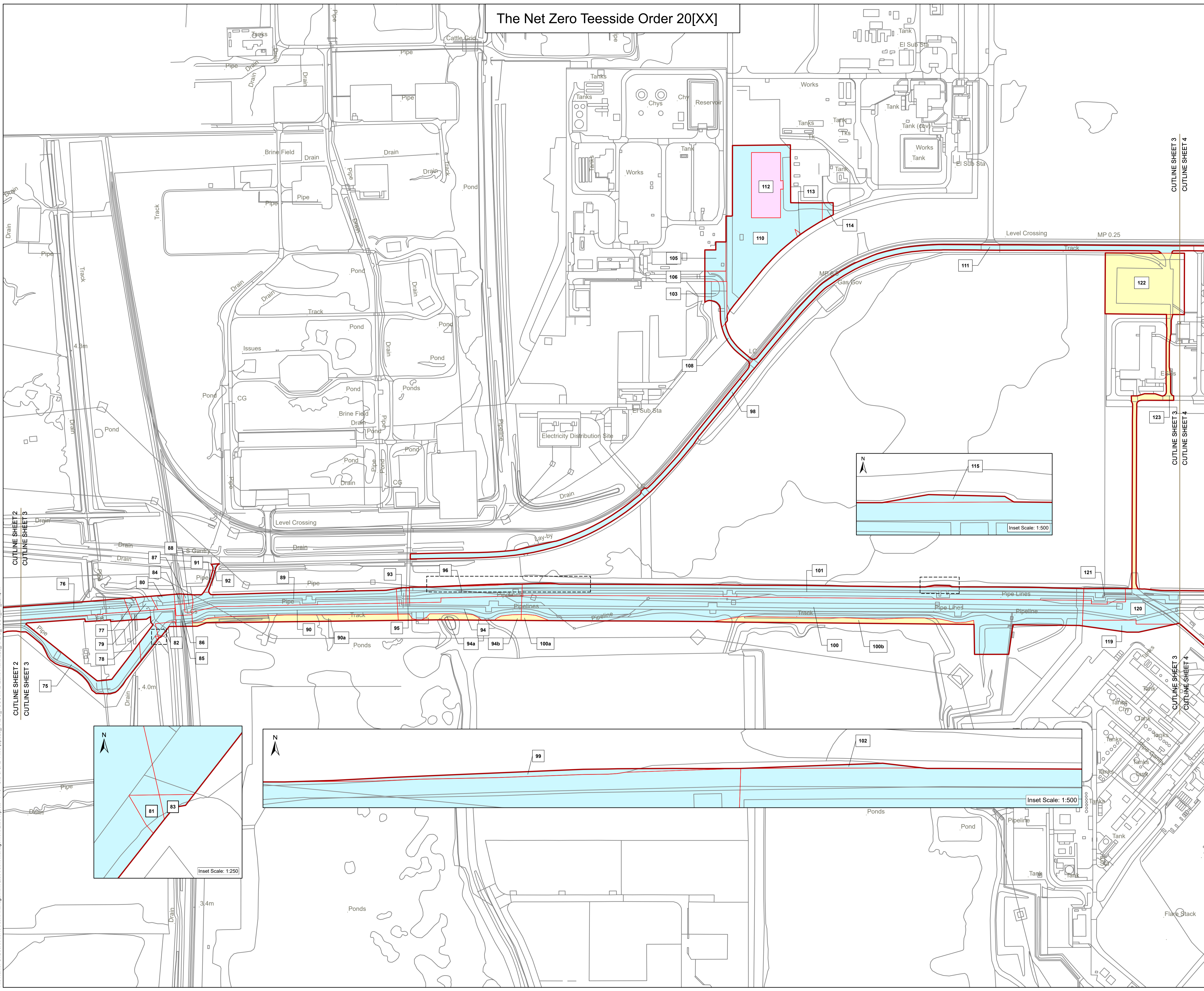

Plot Date: 20 October 2022 15:11
File Name: C:\Users\NHC\Arden Management Ltd\Projects - P16 - GIS & CAD Files (2\026_ARDG_TCCC\KMLand Plans\026_ARDG_TCCC_LP_22.aprx

The Net Zero Teesside Order 20[XX]

Regulation 5(2)(i) - Infrastructure Planning
(Applications: Prescribed Forms and Procedure)
Regulations 2009

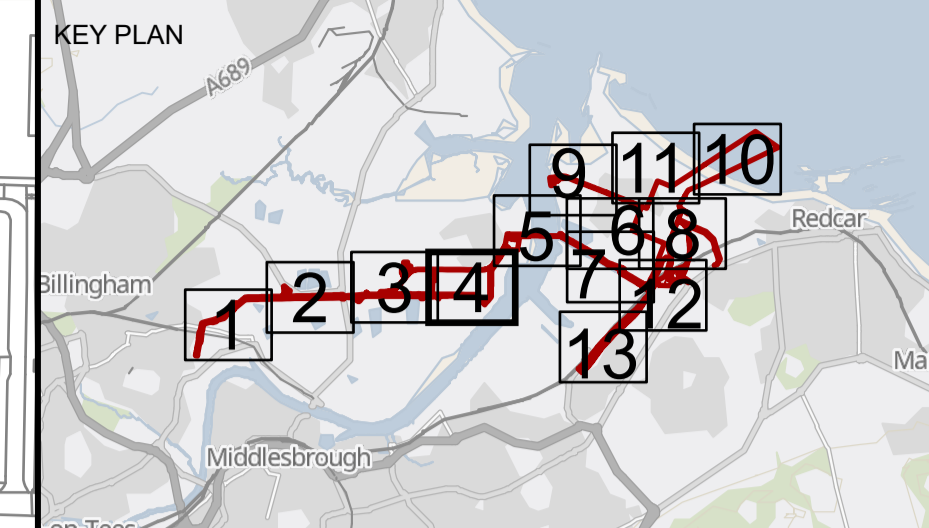

- Key**
- Order Land - the area within which powers of compulsory acquisition and to take temporary possession can be exercised
 - Order Land - New Rights to be compulsorily acquired and in relation to which it is proposed to extinguish easements, servitudes and other private rights.
 - Order Land - Freehold to be compulsorily acquired and in relation to which it is proposed to extinguish easements, servitudes and other private rights.
 - Order Land - Temporary use of land and in relation to which it is proposed to extinguish or suspend easements, servitudes and other private rights.
 - Special Category Land - Open Space

© Crown copyright and database rights 2020 Ordnance Survey 0100031673. You are permitted to use this data solely to enable you to respond to, or interact with, the organisation that provided you with the data. You are not permitted to copy, sub-licence, distribute or sell any of this data to third parties in any form.
GB Background: Contains OS data © Crown Copyright and database right 2022 Contains data from OS Zoomstack

Client: Net Zero Teesside

Clients: **NZT Power Limited & NZNS Storage Limited**

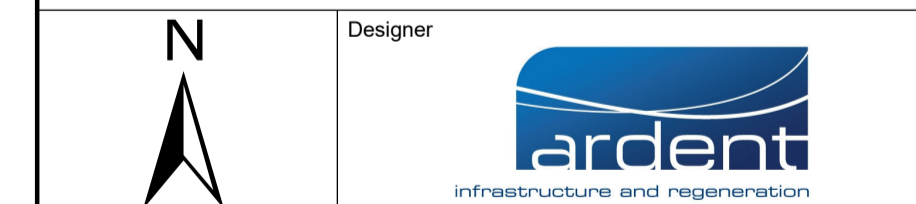

Project: **NET ZERO TEESIDE PROJECT**

Drawing Title: **APPLICATION DOCUMENT REFERENCE NO. 4.2
LAND PLANS
SHEET 4 OF 13**

Status: FOR INFORMATION	Revision: 05
Scale: 1:2,500 @ A1	Date: October 2022
Spatial Reference System: British National Grid	

Drawn By: N.HENRYS	Checked By: J.WITHINGTON	Approved By: L.HARTIGAN
Drawing reference: 026_ARDG_TCCC_LP		

This document is not to be used in whole or in part other than for the intended purpose and project for which it was prepared and provided.

Plot Date: 20 October 2022 15:11
File Name: C:\Users\NHP\Arden Management Ltd\Projects - P16 - GIS & CAD Files (2)026_ARDG_TCCC\KMLand Plans\026_ARDG_TCCC_LP_22.aprx

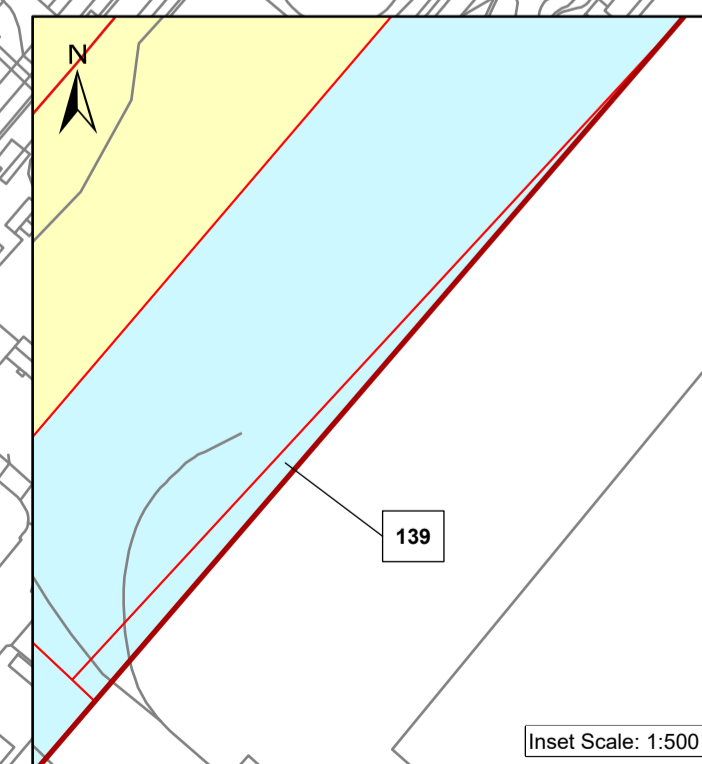
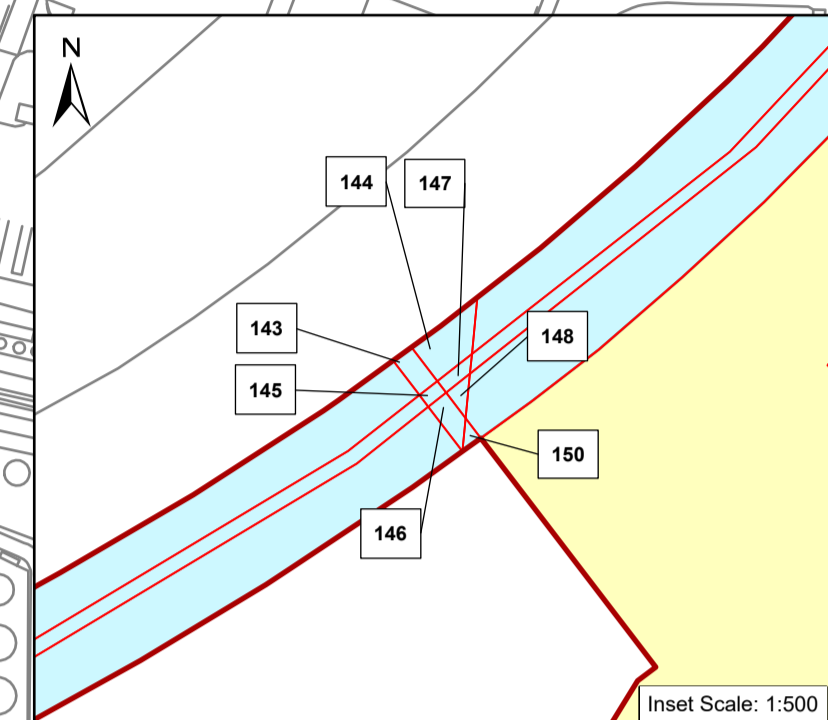
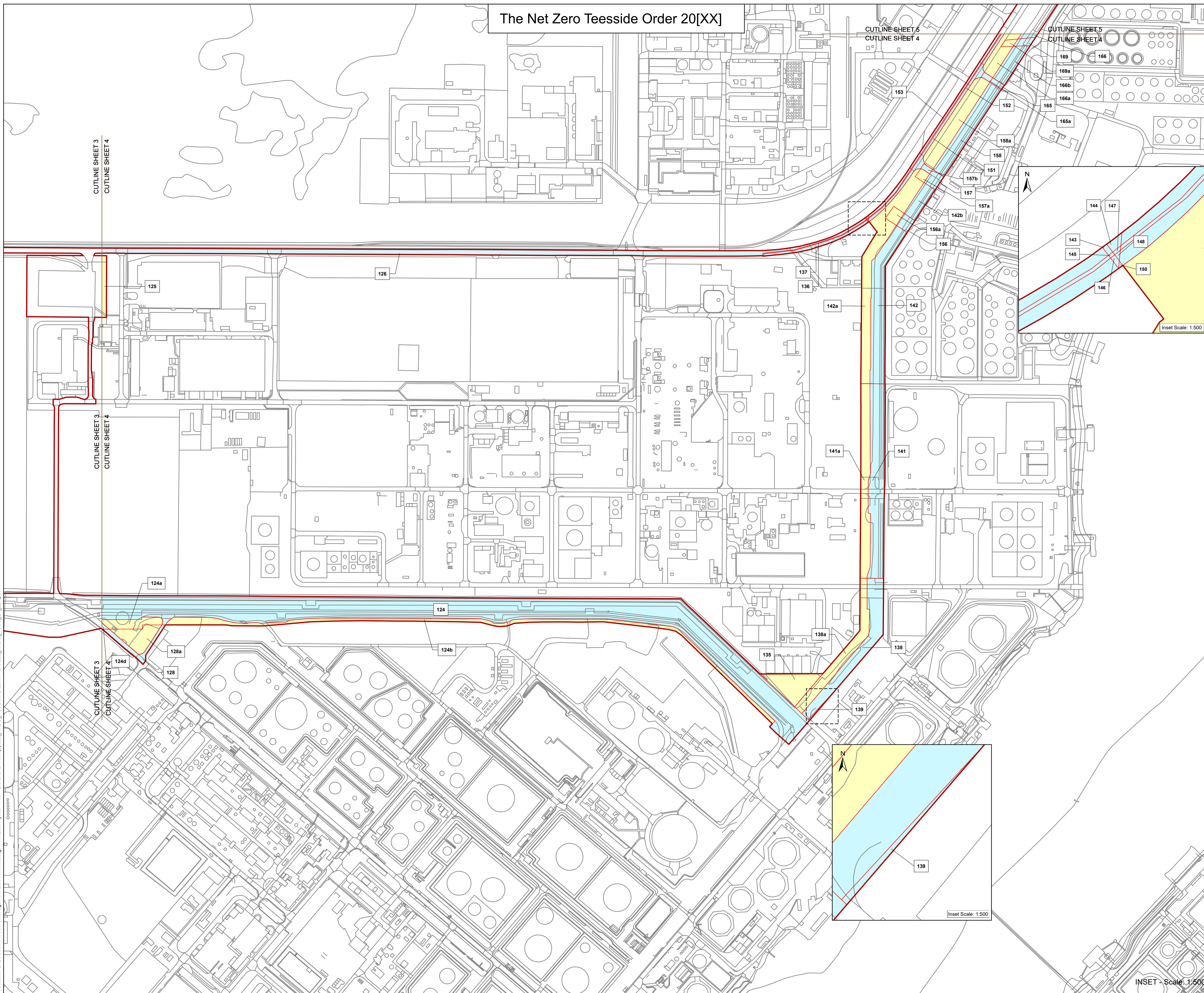

INSET - Scale: 1:500

The Net Zero Teesside Order 20[XX]

Regulation 5(2)(i) - Infrastructure Planning (Applications: Prescribed Forms and Procedure) Regulations 2009

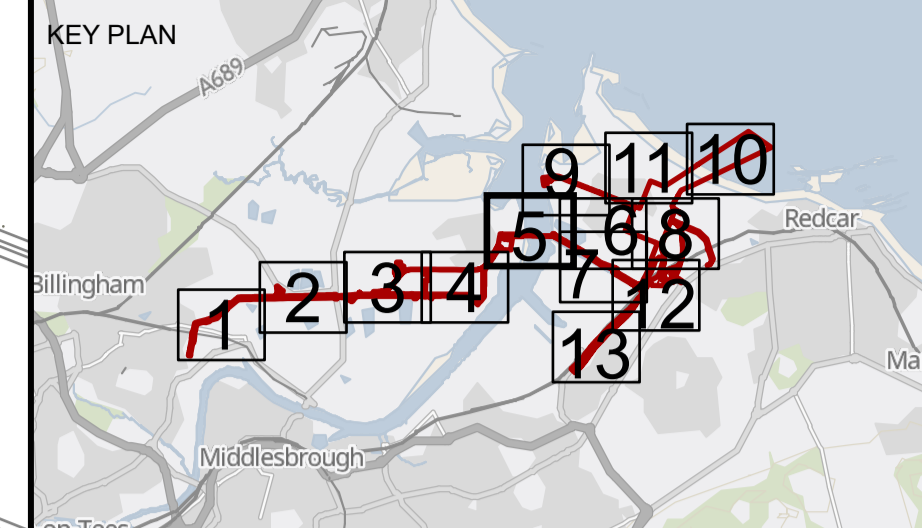

- Key**
- Order Land - the area within which powers of compulsory acquisition and to take temporary possession can be exercised
 - Order Land - New Rights to be compulsorily acquired and in relation to which it is proposed to extinguish easements, servitudes and other private rights.
 - Order Land - Freehold to be compulsorily acquired and in relation to which it is proposed to extinguish easements, servitudes and other private rights.
 - Order Land - Temporary use of land and in relation to which it is proposed to extinguish or suspend easements, servitudes and other private rights.
 - Special Category Land - Open Space

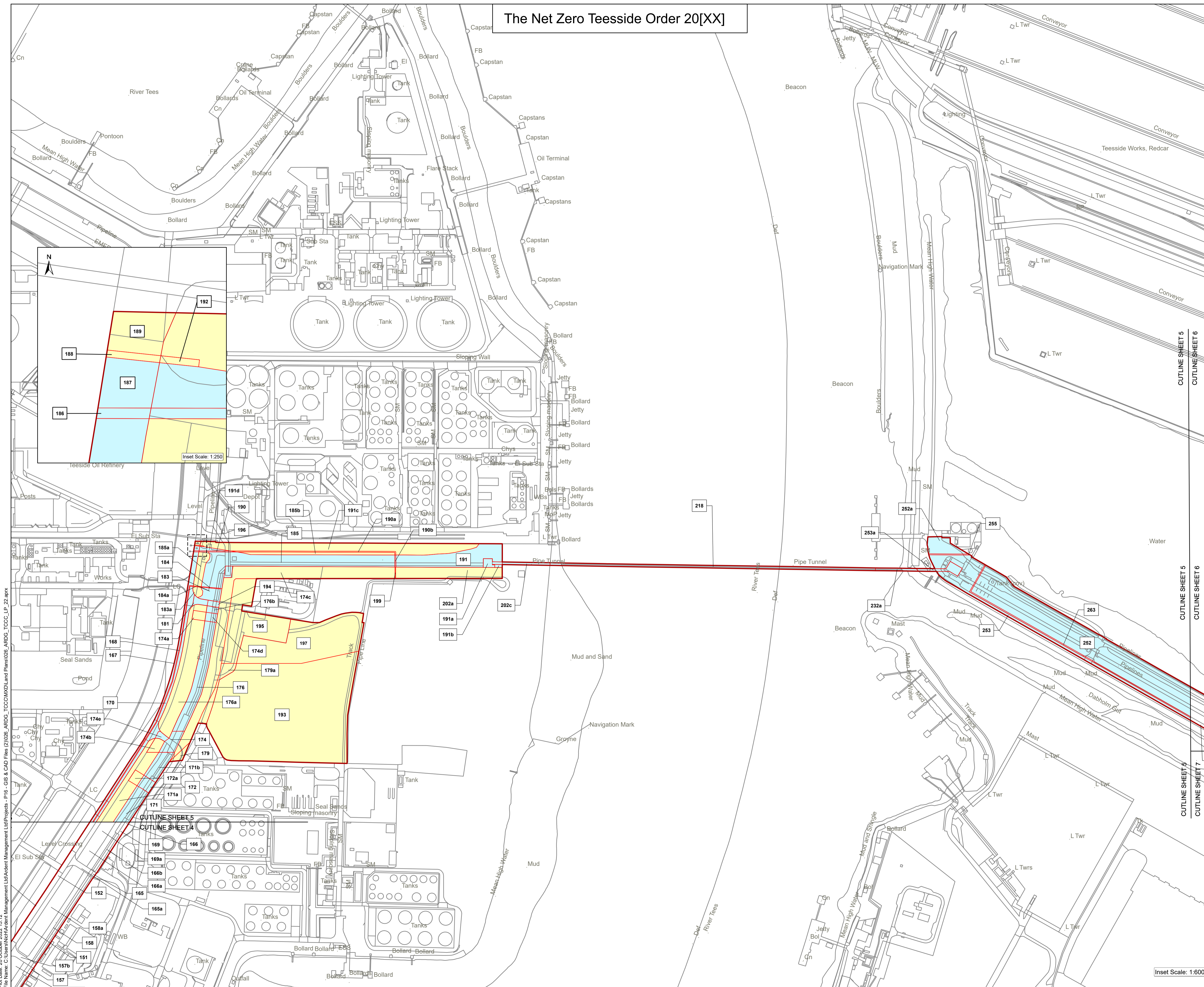

© Crown copyright and database rights 2020 Ordnance Survey 0100031673. You are permitted to use this data solely to enable you to respond to, or interact with, the organisation that provided you with the data. You are not permitted to copy, sub-licence, distribute or sell any of this data to third parties in any form.
GB Background: Contains OS data © Crown Copyright and database right 2022. Contains data from OS Zoomstack.

Client: **Net Zero Teesside**

Clients: **NZT Power Limited & NZNS Storage Limited**
Designer: **ardent**
infrastructure and regeneration

Project: **NET ZERO TEESIDE PROJECT**

Drawing Title: **APPLICATION DOCUMENT REFERENCE NO. 4.2 LAND PLANS SHEET 5 OF 13**

Status	FOR INFORMATION	Revision	05
Date	October 2022	Date	October 2022
Scale	1:2,500 @ A1	Spatial Reference System	British National Grid
Drawn By	I.MAXIM	Checked By	J.WITHINGTON
Approved By	L.HARTIGAN		
Drawing reference	026_ARDG_TCCC_LP		

This document is not to be used in whole or in part other than for the intended purpose and project for which it was prepared and provided.

Plot Date: 20 October 2022 15:12
 File Name: C:\Users\NZArdent\Management Lfd\Arden Management Lfd\Projects - P16 - GIS & CAD Files (2026_ARDG_TCCC)\MXD\Land Plans\026_ARDG_TCCC_LP_22.aprx

Inset Scale: 1:600

The Net Zero Teesside Order 20[XX]

Regulation 5(2)(i) - Infrastructure Planning
(Applications: Prescribed Forms and Procedure)
Regulations 2009

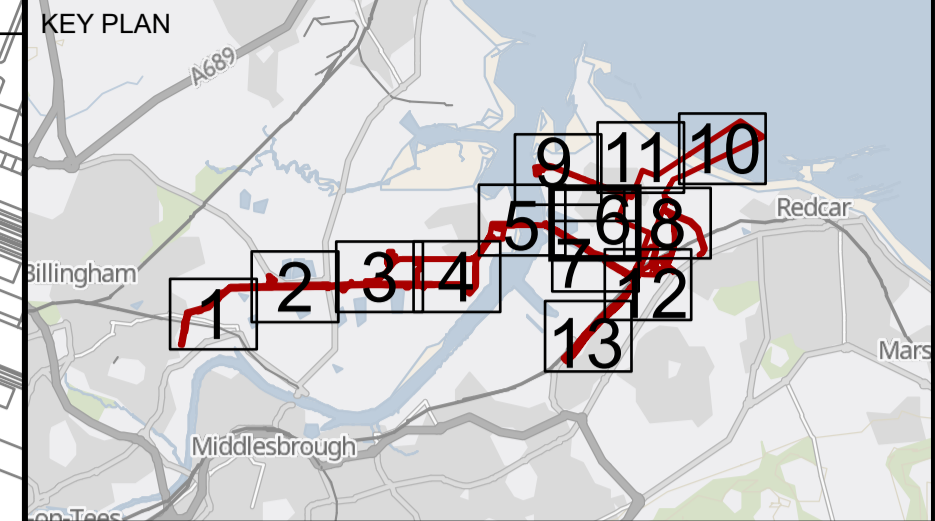

- Key**
- Order Land - the area within which powers of compulsory acquisition and to take temporary possession can be exercised
 - Order Land - New Rights to be compulsorily acquired and in relation to which it is proposed to extinguish easements, servitudes and other private rights.
 - Order Land - Freehold to be compulsorily acquired and in relation to which it is proposed to extinguish easements, servitudes and other private rights.
 - Order Land - Temporary use of land and in relation to which it is proposed to extinguish or suspend easements, servitudes and other private rights.
 - Special Category Land - Open Space

© Crown copyright and database rights 2020 Ordnance Survey 0100031673. You are permitted to use this data solely to enable you to respond to, or interact with, the organisation that provided you with the data. You are not permitted to copy, sub-licence, distribute or sell any of this data to third parties in any form.
GB Background: Contains OS data © Crown Copyright and database right 2022 Contains data from OS Zoomstack

Client: Net Zero Teesside

Clients: **NZT Power Limited & NZNS Storage Limited**

Designer: ardent
infrastructure and regeneration

Project: **NET ZERO TEESSIDE PROJECT**

Drawing Title: **APPLICATION DOCUMENT REFERENCE NO. 4.2
LAND PLANS
SHEET 6 OF 13**

Status	FOR INFORMATION	Revision	05
Date	October 2022	Date	October 2022
Scale	1:2,500 @ A1	Spatial Reference System	British National Grid

Drawn By	Checked By	Approved By
N.HENRYS	J.WITHINGTON	L.HARTIGAN

Drawing reference: **026_Ardg_TCCC_LP**

This document is not to be used in whole or in part other than for the intended purpose and project for which it was prepared and provided.



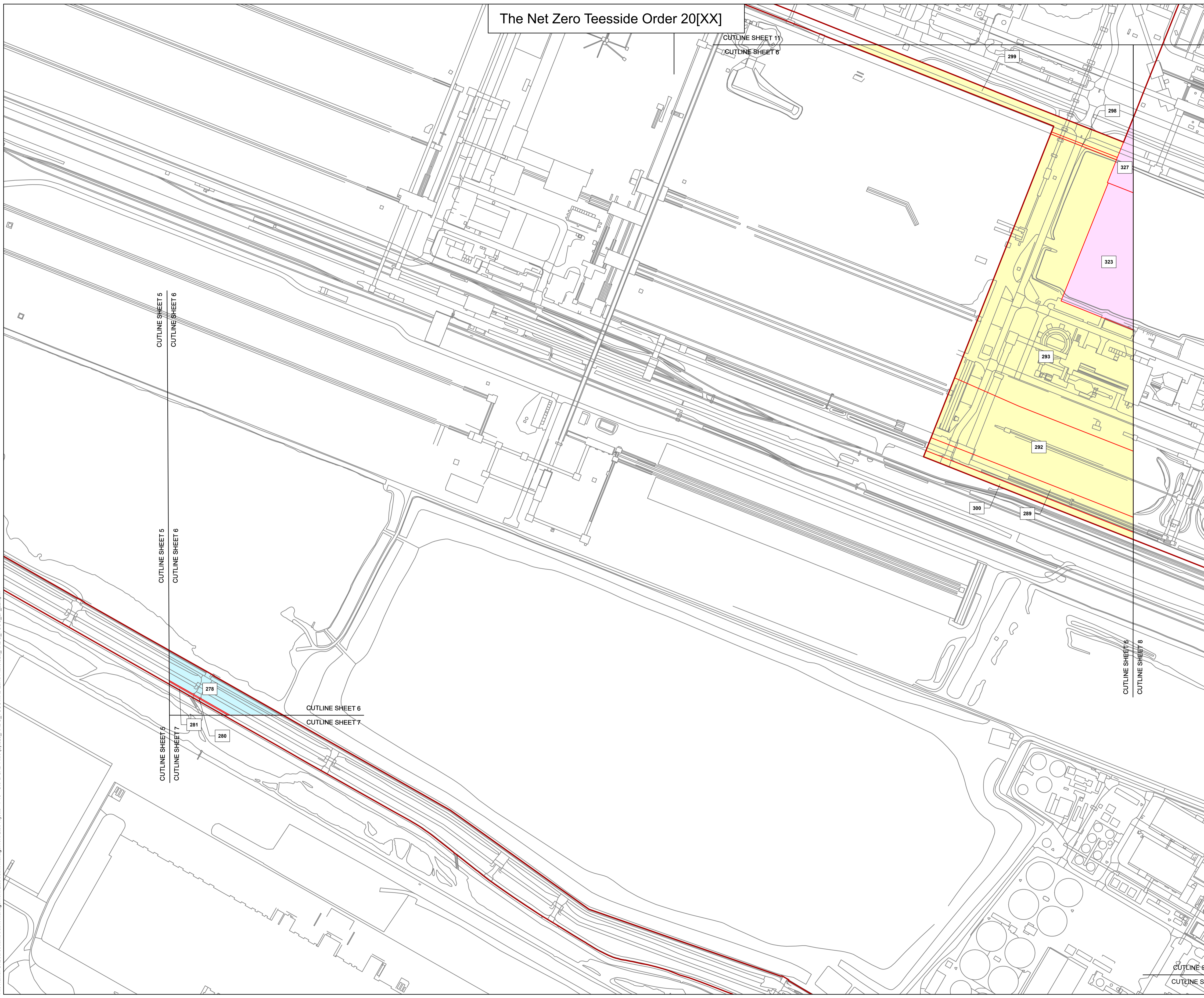

Plot Date: 20 October 2022 15:08
File Name: C:\Users\N1\OneDrive\Documents\Projects - P16 - GIS & CAD Files (2)\026_Ardg_TCCC\KMLand Plans\026_Ardg_TCCC_LP_22.aprx

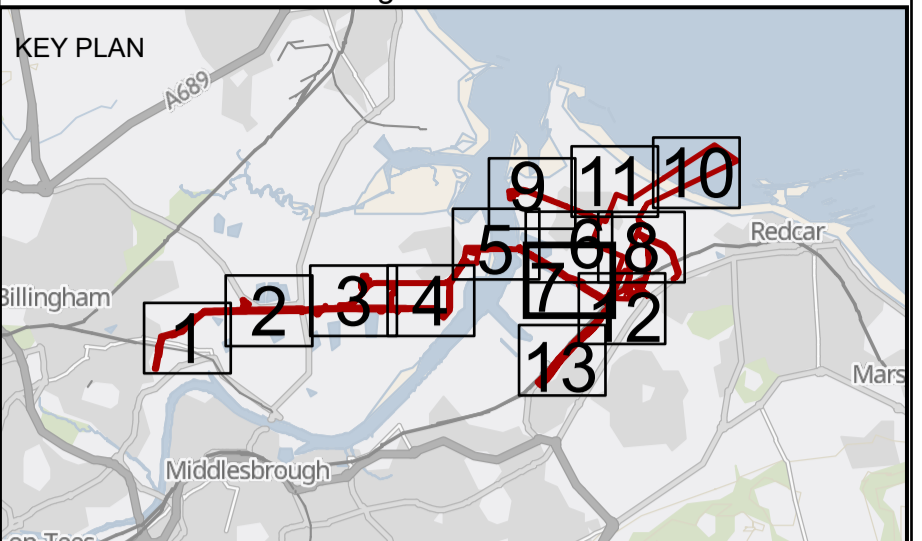

The Net Zero Teesside Order 20[XX]

Regulation 5(2)(i) - Infrastructure Planning
(Applications: Prescribed Forms and Procedure)
Regulations 2009



- Key**
-  Order Land - the area within which powers of compulsory acquisition and to take temporary possession can be exercised
 -  Order Land - New Rights to be compulsorily acquired and in relation to which it is proposed to extinguish easements, servitudes and other private rights.
 -  Order Land - Freehold to be compulsorily acquired and in relation to which it is proposed to extinguish easements, servitudes and other private rights.
 -  Order Land - Temporary use of land and in relation to which it is proposed to extinguish or suspend easements, servitudes and other private rights.
 -  Special Category Land - Open Space

© Crown copyright and database rights 2020 Ordnance Survey 0100031673. You are permitted to use this data solely to enable you to respond to, or interact with, the organisation that provided you with the data. You are not permitted to copy, sub-licence, distribute or sell any of this data to third parties in any form.
GB Background: Contains OS data © Crown Copyright and database right 2022
Contains data from OS Zoomstack

Client

Clients
NZT Power Limited & NZNS Storage Limited

Designer

Project
NET ZERO TEESIDE PROJECT

Drawing Title
**APPLICATION DOCUMENT REFERENCE NO. 4.2
LAND PLANS
SHEET 7 OF 13**

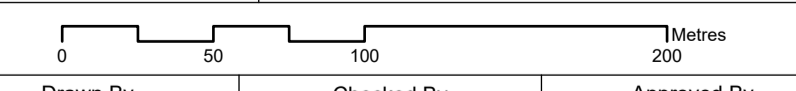
Status	FOR INFORMATION	Revision	05
Date	October 2022	Date	October 2022
Scale	1:2,500 @ A1	Spatial Reference System	British National Grid
			
Drawn By	N.HENRY	Checked By	J.WITHINGTON
Approved By	L.HARTIGAN		
Drawing reference	026_ARDG_TCCC_LP		

This document is not to be used in whole or in part other than for the intended purpose and project for which it was prepared and provided.

Plot Date: 20 October 2022 15:09
 File Name: C:\Users\N16\OneDrive\Work\Projects - P16 - GIS & CAD Files\2\026_ARDG_TCCC\KMLand Plans\026_ARDG_TCCC_LP_22.aprx

The Net Zero Teesside Order 20[XX]

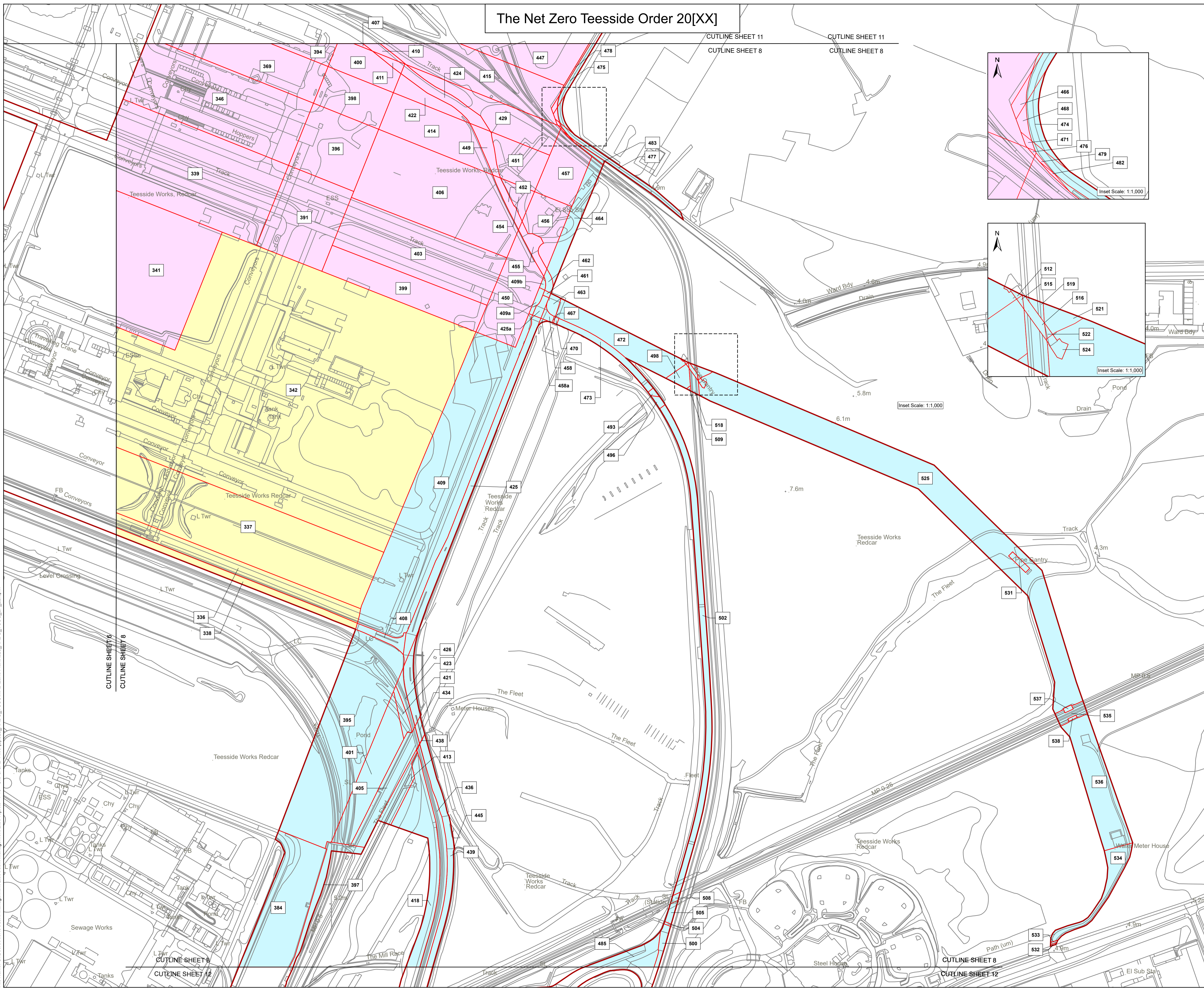

Regulation 5(2)(i) - Infrastructure Planning (Applications: Prescribed Forms and Procedure) Regulations 2009

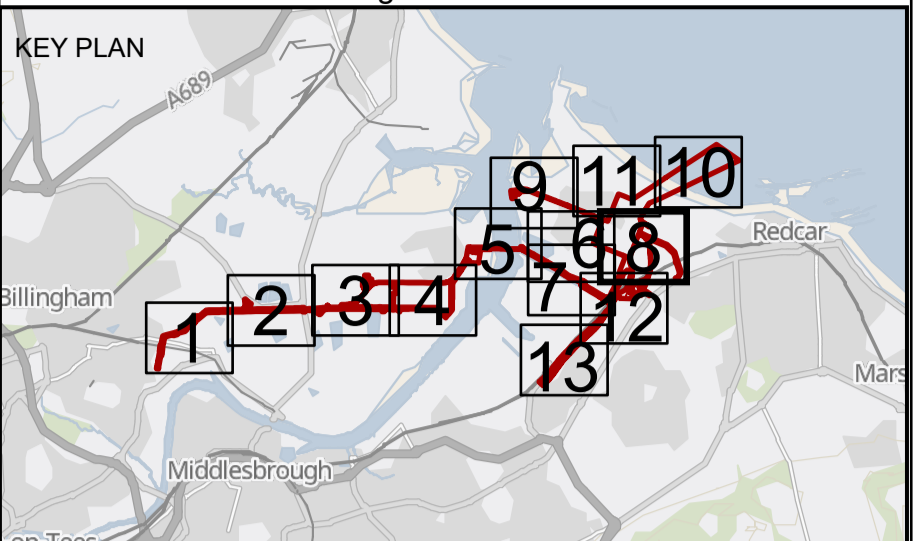

- Key**
- Order Land - the area within which powers of compulsory acquisition and to take temporary possession can be exercised
 - Order Land - New Rights to be compulsorily acquired and in relation to which it is proposed to extinguish easements, servitudes and other private rights.
 - Order Land - Freehold to be compulsorily acquired and in relation to which it is proposed to extinguish easements, servitudes and other private rights.
 - Order Land - Temporary use of land and in relation to which it is proposed to extinguish or suspend easements, servitudes and other private rights.
 - Special Category Land - Open Space

© Crown copyright and database rights 2020 Ordnance Survey 0100031673. You are permitted to use this data solely to enable you to respond to, or interact with, the organisation that provided you with the data. You are not permitted to copy, sub-licence, distribute or sell any of this data to third parties in any form.
GB Background: Contains OS data © Crown Copyright and database right 2022 Contains data from OS Zoomstack

Client: Net Zero Teesside

Clients: **NZT Power Limited & NZNS Storage Limited**

Designer: ardent infrastructure and regeneration

Project: **NET ZERO TEESIDE PROJECT**

Drawing Title: **APPLICATION DOCUMENT REFERENCE NO. 4.2 LAND PLANS SHEET 8 OF 13**

Status	FOR INFORMATION	Revision	05
Date		Date	October 2022
Scale	1:2,500 @ A1	Spatial Reference System	British National Grid
Drawn By	I.MAXIM	Checked By	J.WITHINGTON
		Approved By	L.HARTIGAN
Drawing reference	026_ARDG_TCCG_LP		





This document is not to be used in whole or in part other than for the intended purpose and project for which it was prepared and provided.

Plot Date: 20 October 2022, 15:20
File Name: C:\Users\NIE\ArdenManagement Ltd\ArdenManagement Ltd\Projects - P16 - GIS & CAD Files (2\026_ARDG_TCCG)\MKD\land Plans\026_ARDG_TCCG_LP_22.aprx

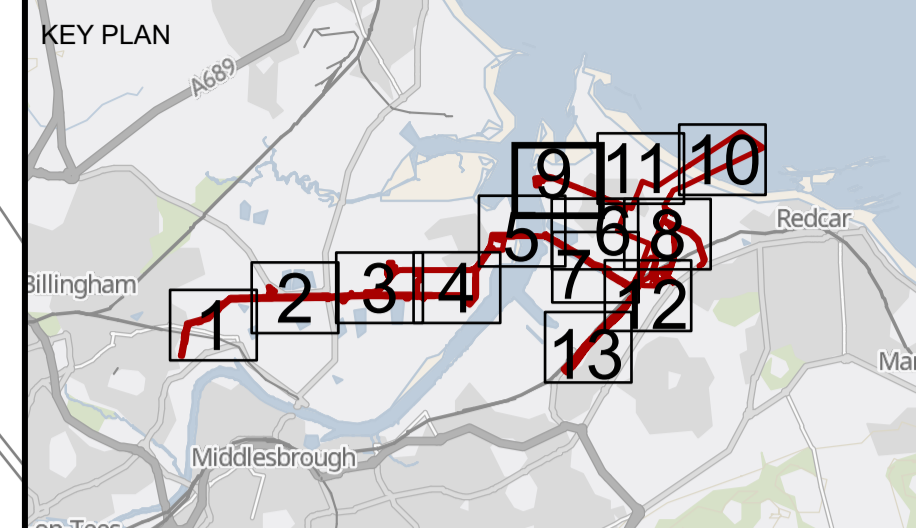
The Net Zero Teesside Order 20[XX]

Regulation 5(2)(i) - Infrastructure Planning
(Applications: Prescribed Forms and Procedure)
Regulations 2009



- Key**
-  Order Land - the area within which powers of compulsory acquisition and to take temporary possession can be exercised
 -  Order Land - New Rights to be compulsorily acquired and in relation to which it is proposed to extinguish easements, servitudes and other private rights.
 -  Order Land - Freehold to be compulsorily acquired and in relation to which it is proposed to extinguish easements, servitudes and other private rights.
 -  Order Land - Temporary use of land and in relation to which it is proposed to extinguish or suspend easements, servitudes and other private rights.
 -  Special Category Land - Open Space



© Crown copyright and database rights 2020 Ordnance Survey 0100031673. You are permitted to use this data solely to enable you to respond to, or interact with, the organisation that provided you with the data. You are not permitted to copy, sub-licence, distribute or sell any of this data to third parties in any form.
GB Background: Contains OS data © Crown Copyright and database right 2022. Contains data from OS Zoomstack

Client:  Net Zero Teesside

Clients: **NZT Power Limited & NZNS Storage Limited**

Designer:  ardent
infrastructure and regeneration

Project: **NET ZERO TEESIDE PROJECT**

Drawing Title: **APPLICATION DOCUMENT REFERENCE NO. 4.2
LAND PLANS
SHEET 9 OF 13**

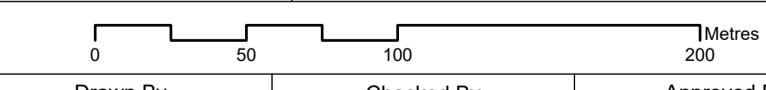
Status	FOR INFORMATION	Revision	05
Date	October 2002		
Scale	1:2,500 @ A1	Spatial Reference System	British National Grid
			
Drawn By	N.HENRYS	Checked By	J.WITHINGTON
Approved By	L.HARTIGAN		
Drawing reference	026_ARDG_TCCC_LP		

This document is not to be used in whole or in part other than for the intended purpose and project for which it was prepared and provided.



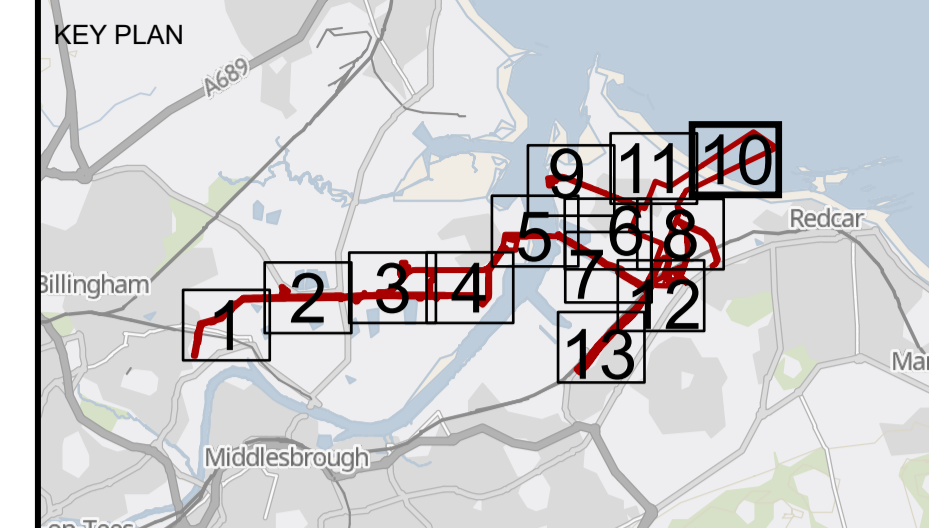

Plot Date: 20 October 2022 15:09
 File Name: C:\Users\Nict\Arden Management Ltd\Arden Management Ltd\Projects - P16 - GIS & CAD Files\2\026_ARDG_TCCC\MKD\land Plans\026_ARDG_TCCC_LP_22.aprx

The Net Zero Teesside Order 20[XX]

Regulation 5(2)(i) - Infrastructure Planning
(Applications: Prescribed Forms and Procedure)
Regulations 2009



Key

-  Order Land - the area within which powers of compulsory acquisition and to take temporary possession can be exercised
-  Order Land - New Rights to be compulsorily acquired and in relation to which it is proposed to extinguish easements, servitudes and other private rights.
-  Order Land - Freehold to be compulsorily acquired and in relation to which it is proposed to extinguish easements, servitudes and other private rights.
-  Order Land - Temporary use of land and in relation to which it is proposed to extinguish or suspend easements, servitudes and other private rights.
-  Special Category Land - Open Space

© Crown copyright and database rights 2020 Ordnance Survey 0100031673. You are permitted to use this data solely to enable you to respond to, or interact with, the organisation that provided you with the data. You are not permitted to copy, sub-licence, distribute or sell any of this data to third parties in any form.
GB Background: Contains OS data © Crown Copyright and database right 2022
Contains data from OS Zoomstack

Client 

Clients **NZT Power Limited & NZNS Storage Limited**

Designer 

Project **NET ZERO TEESSIDE PROJECT**

Drawing Title
**APPLICATION DOCUMENT REFERENCE NO. 4.2
LAND PLANS
SHEET 10 OF 13**

Status	FOR INFORMATION	Revision	05
Date	October 2002		

Scale	1:2,500 @ A1	Spatial Reference System	British National Grid
-------	--------------	--------------------------	-----------------------

Drawn By	Checked By	Approved By
N.HENRY	J.WITHINGTON	L.HARTIGAN

Drawing reference **026_ARDG_TCCC_LP**

This document is not to be used in whole or in part other than for the intended purpose and project for which it was prepared and provided.

Plot Date: 20 October 2022, 15:09
File Name: C:\Users\N16\Arden\Management Ltd\Projects - P16 - GIS & CAD Files (2\026_ARDG_TCCC\KMLand Plans\026_ARDG_TCCC_LP_22.aprx

CUTLINE SHEET 11
CUTLINE SHEET 10

529

528

527





539

530

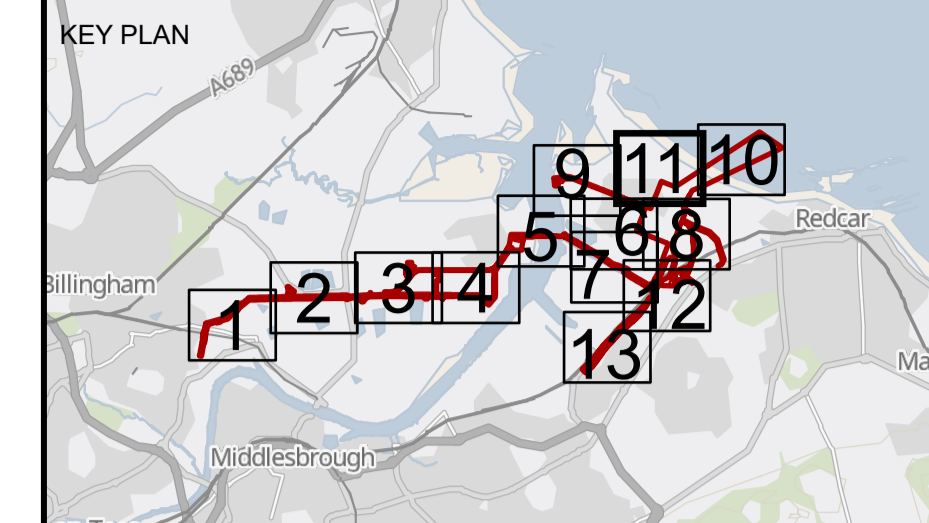
The Net Zero Teesside Order 20[XX]

Regulation 5(2)(i) - Infrastructure Planning
(Applications: Prescribed Forms and Procedure)
Regulations 2009



- Key**
-  Order Land - the area within which powers of compulsory acquisition and to take temporary possession can be exercised
 -  Order Land - New Rights to be compulsorily acquired and in relation to which it is proposed to extinguish easements, servitudes and other private rights.
 -  Order Land - Freehold to be compulsorily acquired and in relation to which it is proposed to extinguish easements, servitudes and other private rights.
 -  Order Land - Temporary use of land and in relation to which it is proposed to extinguish or suspend easements, servitudes and other private rights.
 -  Special Category Land - Open Space

© Crown copyright and database rights 2020 Ordnance Survey 0100031673. You are permitted to use this data solely to enable you to respond to, or interact with, the organisation that provided you with the data. You are not permitted to copy, sub-licence, distribute or sell any of this data to third parties in any form.
GB Background: Contains OS data © Crown Copyright and database right 2022
Contains data from OS Zoomstack

Client
 Net Zero Teesside

Clients
NZT Power Limited & NZNS Storage Limited

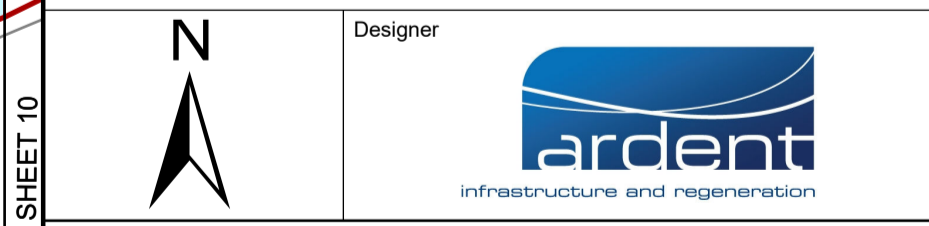

Project
NET ZERO TEESIDE PROJECT

Drawing Title
**APPLICATION DOCUMENT REFERENCE NO. 4.2
LAND PLANS
SHEET 11 OF 13**

Status	FOR INFORMATION	Revision	05
Date	October 2022	Date	October 2022

Scale: 1:2,500 @ A1 | Spatial Reference System: British National Grid

Drawn By	Checked By	Approved By
N.HENRYS	J.WITHINGTON	L.HARTIGAN

Drawing reference: 026_ARDG_TCCC_LP

This document is not to be used in whole or in part other than for the intended purpose and project for which it was prepared and provided.

Plot Date: 20 October 2022 15:09
File Name: C:\Users\NHC\Arden Management Ltd\Arden Management Ltd\Projects - P16 - GIS & CAD Files (2\026_ARDG_TCCC\KMLand Plans\026_ARDG_TCCC_LP_22.aprx

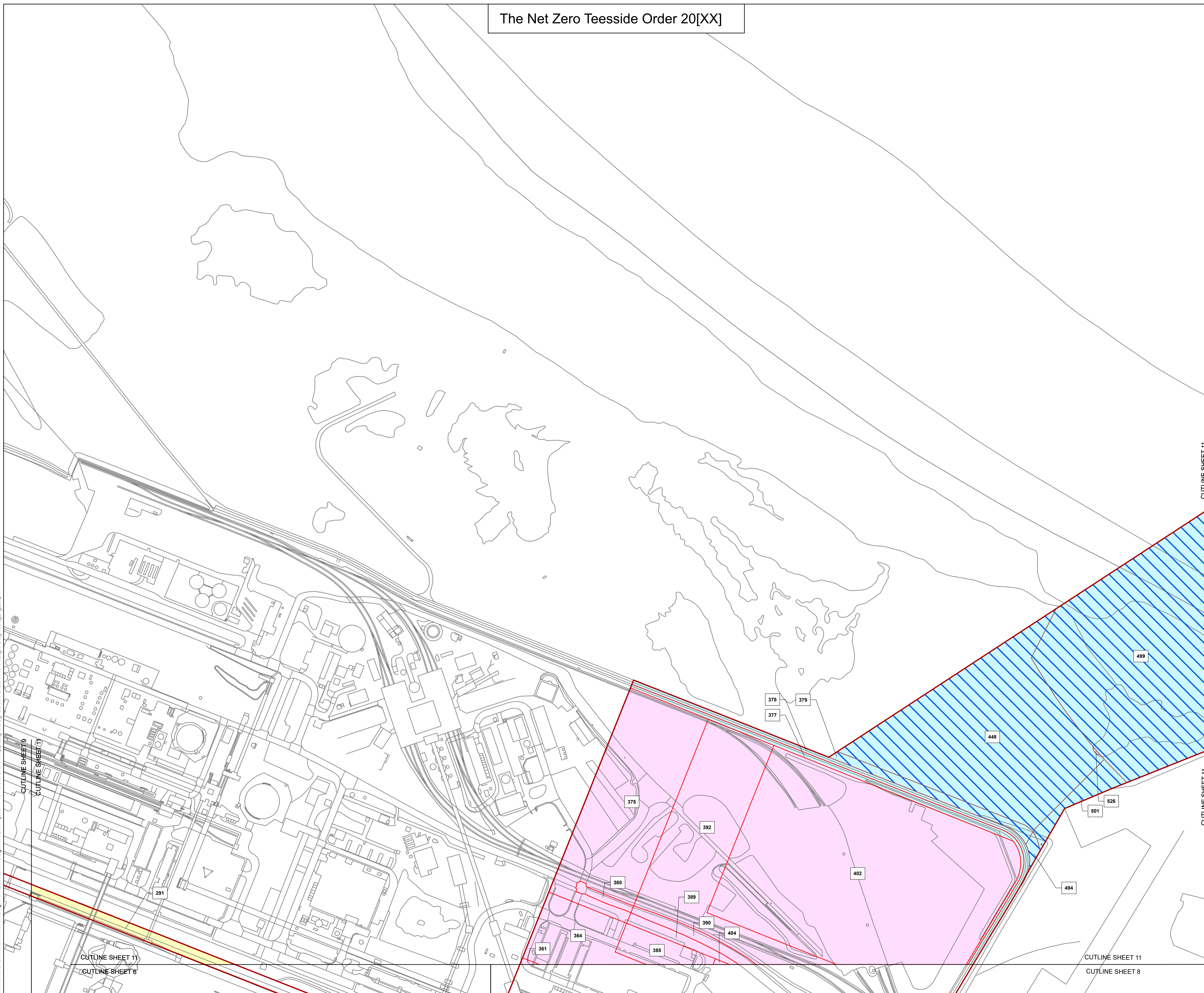

CUTLINE SHEET 11
CUTLINE SHEET 6

CUTLINE SHEET 11
CUTLINE SHEET 8

CUTLINE SHEET 11
CUTLINE SHEET 10
CUTLINE SHEET 11
CUTLINE SHEET 10
CUTLINE SHEET 11
CUTLINE SHEET 10

The Net Zero Teesside Order 20[XX]

Regulation 5(2)(i) - Infrastructure Planning (Applications: Prescribed Forms and Procedure) Regulations 2009

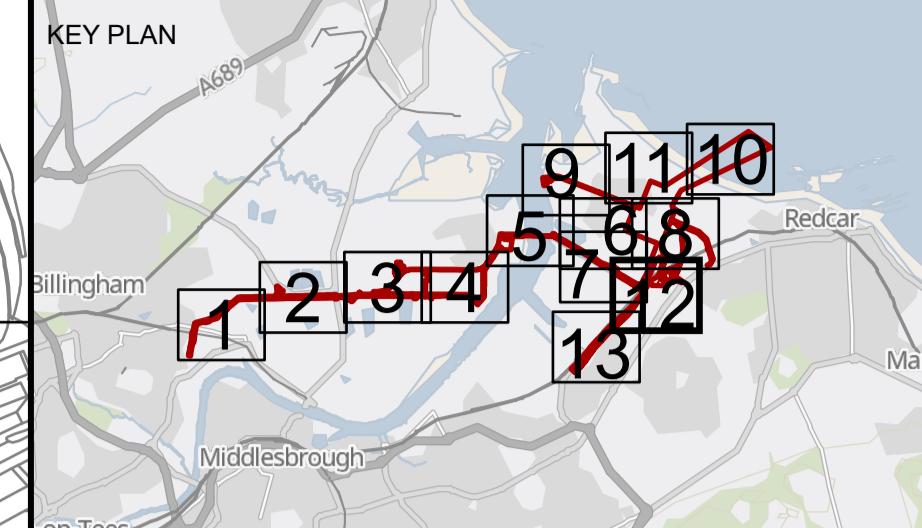

- Key**
- Order Land - the area within which powers of compulsory acquisition and to take temporary possession can be exercised
 - Order Land - New Rights to be compulsorily acquired and in relation to which it is proposed to extinguish easements, servitudes and other private rights.
 - Order Land - Freehold to be compulsorily acquired and in relation to which it is proposed to extinguish easements, servitudes and other private rights.
 - Order Land - Temporary use of land and in relation to which it is proposed to extinguish or suspend easements, servitudes and other private rights.
 - Special Category Land - Open Space

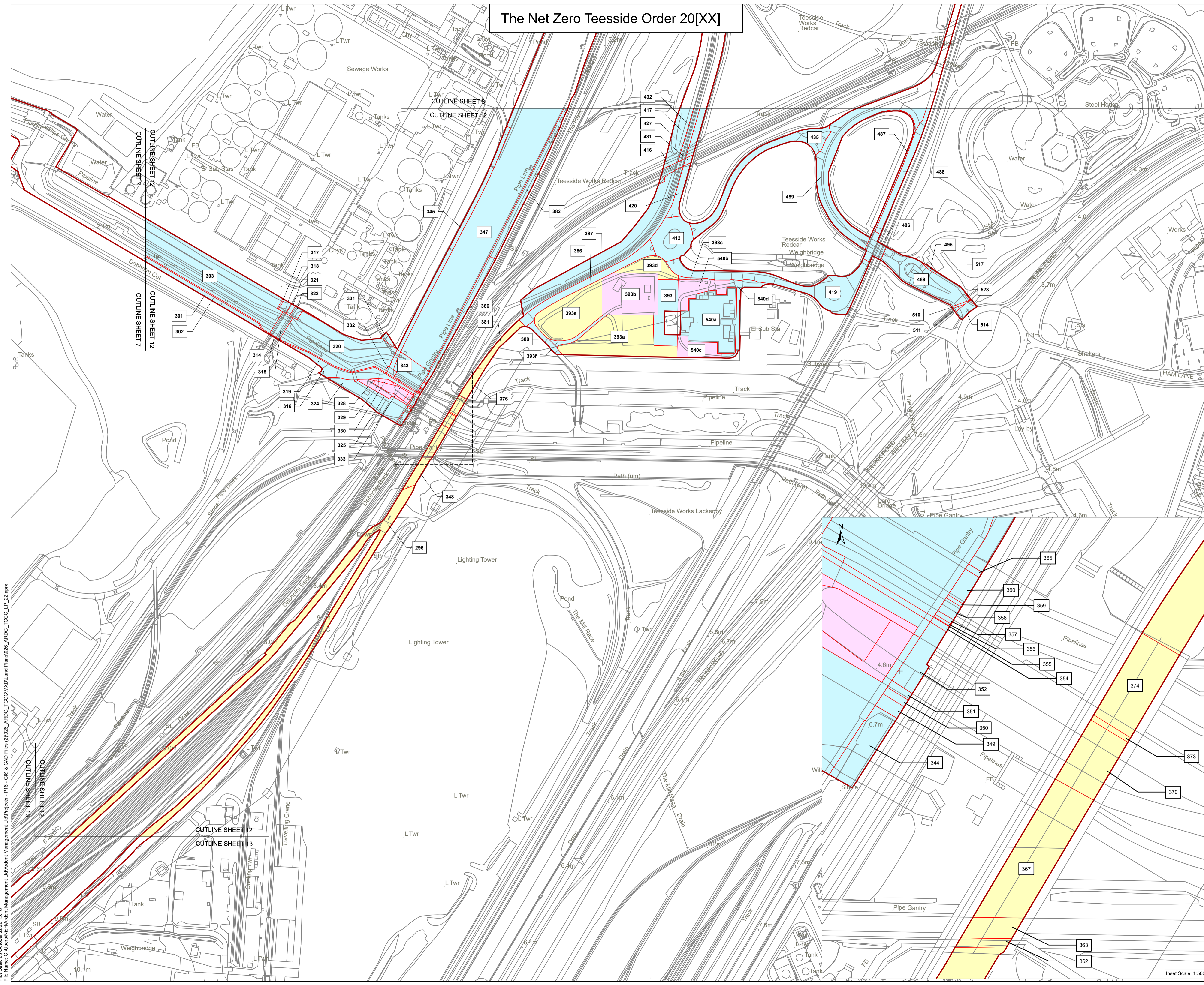

© Crown copyright and database rights 2020 Ordnance Survey 0100031673. You are permitted to use this data solely to enable you to respond to, or interact with, the organisation that provided you with the data. You are not permitted to copy, sub-licence, distribute or sell any of this data to third parties in any form.
GB Background: Contains OS data © Crown Copyright and database right 2022. Contains data from OS Zoomstack

Client: Net Zero Teesside

Clients: **NZT Power Limited & NZNS Storage Limited**
Designer: ardent infrastructure and regeneration

Project: **NET ZERO TEESIDE PROJECT**

Drawing Title: **APPLICATION DOCUMENT REFERENCE NO. 4.2 LAND PLANS SHEET 12 OF 13**

Status: FOR INFORMATION	Revision: 05
Scale: 1:2,500 @ A1	Date: October 2022
Spatial Reference System: British National Grid	

Drawn By: N.HENRY	Checked By: J.WITHINGTON	Approved By: L.HARTIGAN
Drawing reference: 026_ARDG_TCCC_LP		

This document is not to be used in whole or in part other than for the intended purpose and project for which it was prepared and provided.

Plot Date: 20 October 2022, 15:19
File Name: C:\Users\NHC\Arden Management Ltd\Arden Management Ltd\Projects - P16 - GIS & CAD Files (2\026_ARDG_TCCC\KMLand Plans\026_ARDG_TCCC_LP_22.aprx

The Net Zero Teesside Order 20[XX]

Regulation 5(2)(i) - Infrastructure Planning
(Applications: Prescribed Forms and Procedure)
Regulations 2009

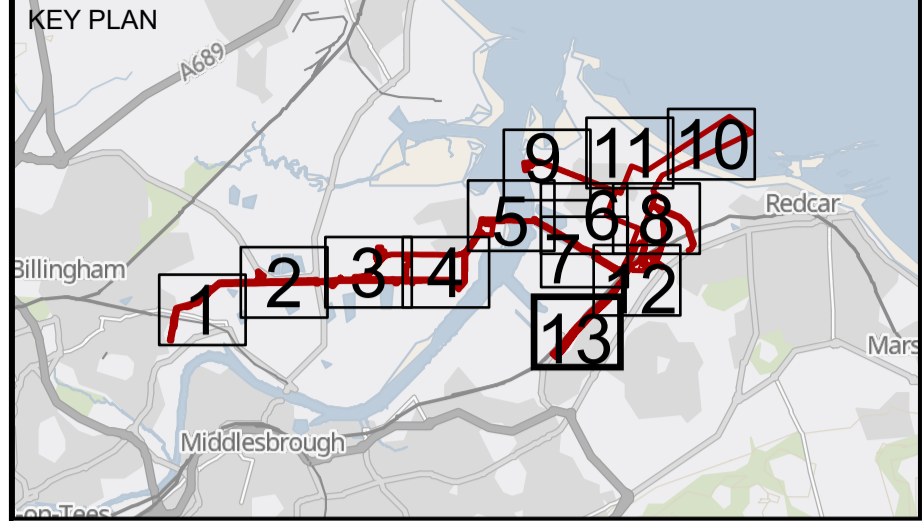

- Key**
- Order Land - the area within which powers of compulsory acquisition and to take temporary possession can be exercised
 - Order Land - New Rights to be compulsorily acquired and in relation to which it is proposed to extinguish easements, servitudes and other private rights.
 - Order Land - Freehold to be compulsorily acquired and in relation to which it is proposed to extinguish easements, servitudes and other private rights.
 - Order Land - Temporary use of land and in relation to which it is proposed to extinguish or suspend easements, servitudes and other private rights.
 - Special Category Land - Open Space

© Crown copyright and database rights 2020 Ordnance Survey 0100031673. You are permitted to use this data solely to enable you to respond to, or interact with, the organisation that provided you with the data. You are not permitted to copy, sub-licence, distribute or sell any of this data to third parties in any form.
GB Background: Contains OS data © Crown Copyright and database right 2022. Contains data from OS Zoomstack

Client: Net Zero Teesside

Clients: **NZT Power Limited & NZNS Storage Limited**



Project: **NET ZERO TEESIDE PROJECT**

Drawing Title: **APPLICATION DOCUMENT REFERENCE NO. 4.2
LAND PLANS
SHEET 13 OF 13**

Status: FOR INFORMATION	Revision: 05
Scale: 1:2,500 @ A1	Date: October 2022
Spatial Reference System: British National Grid	

Drawn By: N.HENRY	Checked By: J.WITHINGTON	Approved By: L.HARTIGAN
Drawing reference: 026_ARDG_TCCC_LP		

This document is not to be used in whole or in part other than for the intended purpose and project for which it was prepared and provided.

Plot Date: 20 October 2022, 15:49
 File Name: C:\Users\NHC\Arden Management Ltd\Projects - F16 - GIS & CAD Files (2\026_ARDG_TCCC\MKD\land Plans\026_ARDG_TCCC_LP_22.aprx

